

# TANQUE PARA PRODUCTO QUÍMICO

## Capacidad: 200 Galones (Nominal)

# TRUWATER®

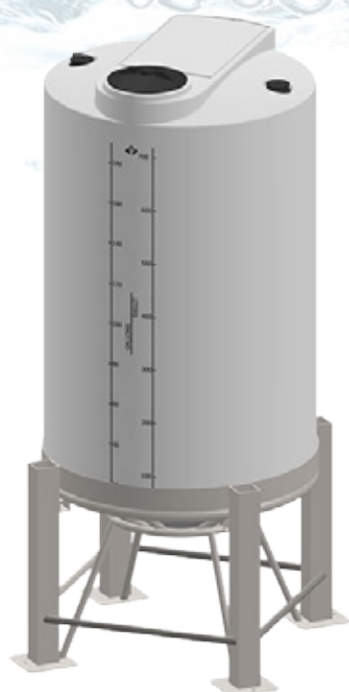

Modelo: TW-TPQ200GL

## ESPECIFICACIONES TÉCNICAS

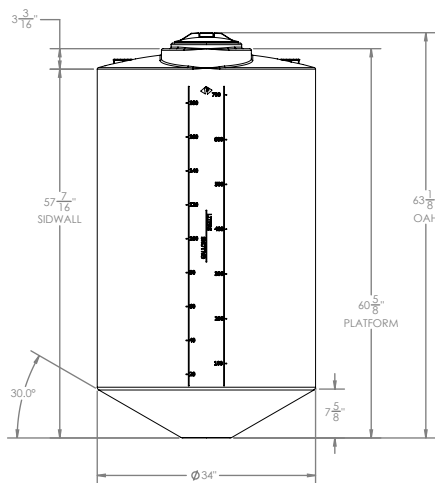
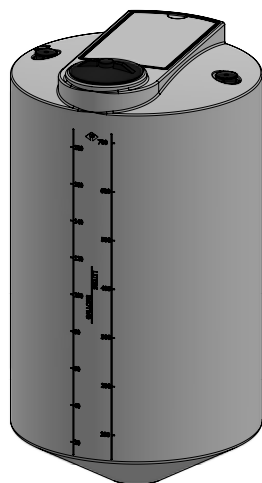

TOP LEVEL ASSEMBLY		
ITEM NO.	DESCRIPTION	QTY.
1	13/4" SPINWELD (FRPT)	1
2	CHEMICAL FEED PUMP MOUNTING AREA	1
3	2" SPINWELD (FRPT)	2
4	8" TWIST LID	1

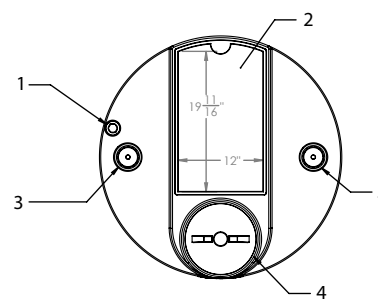

**NOTES:**

1. CAPACITY: 200 GAL. NOMINAL
  2. TANK MATERIAL OPTIONS: LLDPE HDLPE XLPE FDA WATER PPL PVDF
  3. SERVICE PRESSURE: ATMOSPHERIC
  4. NSF/ANSI STANDARD 61 CERTIFIED
  5. AVAILABLE W/ FRP WRAP
- CONTACT CUSTOMER SERVICE FOR ADDITIONAL INFORMATION



Este Tanque para Producto Químico posee las mismas características y beneficios de un tanque cilíndrico, pero un 22% de mayor capacidad que uno cilíndrico del mismo tamaño. Los tanques de plástico son una excelente opción cuando se busca un almacenamiento seguro de químicos y otros productos donde se quiere un sistema de contención secundaria.