

TANQUE PARA PRODUCTO QUÍMICO

Capacidad: 500 Galones (Nominal)

TRUWATER®

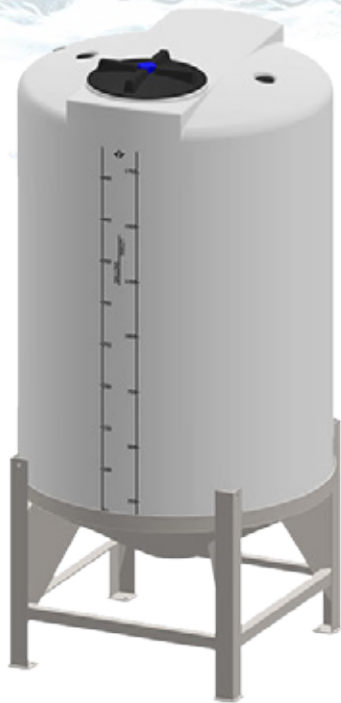

Modelo: TW-TPQ500GL

ESPECIFICACIONES TÉCNICAS

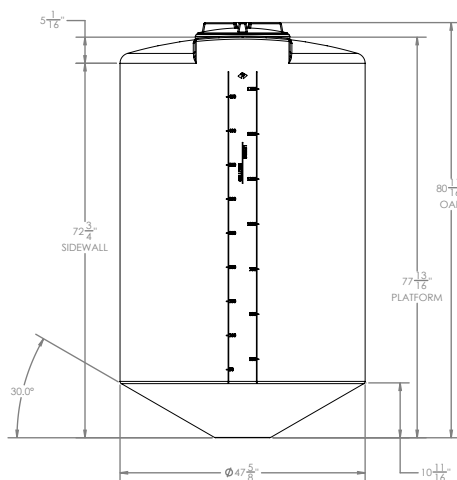
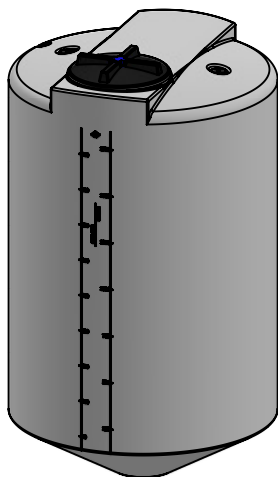

TOP LEVEL ASSEMBLY		
ITEM NO.	DESCRIPTION	QTY.
1	1" SPINWELD (FRPT)	1
2	CHEMICAL FEED PUMP MOUNTING AREA	1
3	2" SPINWELD (FRPT)	2
4	16" TWIST LID	1

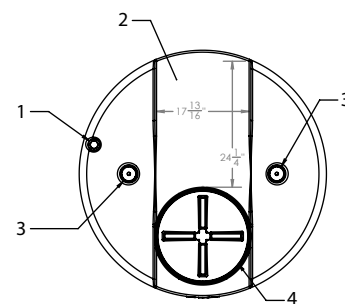

- NOTES:
- CAPACITY: 500 GAL. NOMINAL
 - TANK MATERIAL OPTIONS: LLDPE HDLPE XLPE FDA WATER PPL PVDF
 - SERVICE PRESSURE: ATMOSPHERIC
 - NSF/ANSI STANDARD 61 CERTIFIED
 - AVAILABLE W/ FRP WRAP
- CONTACT CUSTOMER SERVICE FOR ADDITIONAL INFORMATION



Este Tanque para Producto Químico posee las mismas características y beneficios de un tanque cilíndrico, pero un 22% de mayor capacidad que uno cilíndrico del mismo tamaño. Los tanques de plástico son una excelente opción cuando se busca un almacenamiento seguro de químicos y otros productos donde se quiere un sistema de contención secundario.